

bar mixer/speed fit connection kit

Table of Contents

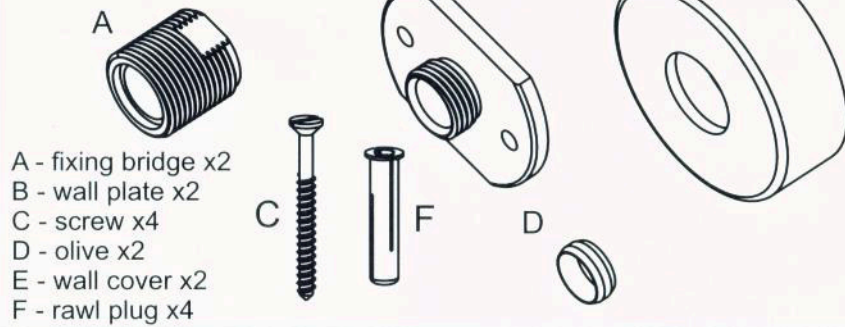

Please check the contents of your purchase with the table of contents (see above)

Stage 1 - The inlet pipes need to be run with 150mm centres between the pipes, before installation of the speed fix kit. You need to ensure you have at least 30mm of copper pipe protruding from the tiled/finished surface. (Diagram 1). Place the wall plate (B) over the pipe and mark the holes location, drill holes To suit fixings.

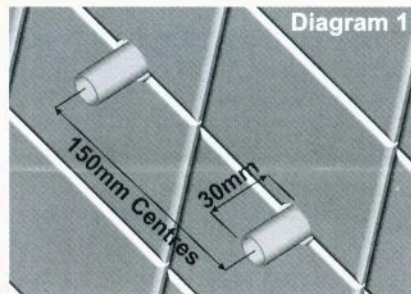
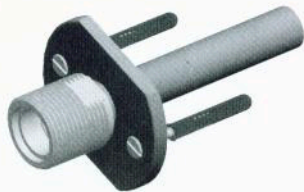

Diagram 2



Stage 2 - Place Wallplate over pipe and onto the wall and tighten up the screws until secure.

Place the olive onto the pipe, the copper pipe needs to protrude past the olive by 5mm maximum.

Stage 3 - Screw the fixing bridge onto the wall plate using a 22mm a/f spanner. Flats have been produced on the wall plate to take a 47mm spanner DO NOT tighten up the fixing bridge against the Screws (Diagram 3).

Note :- For cavity wall installations it may be necessary to use more suitable fixing screws

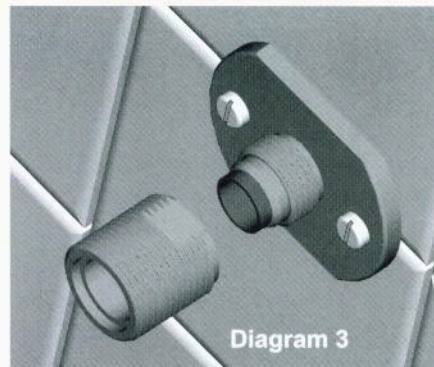

760062-C